

SIDE VIEW

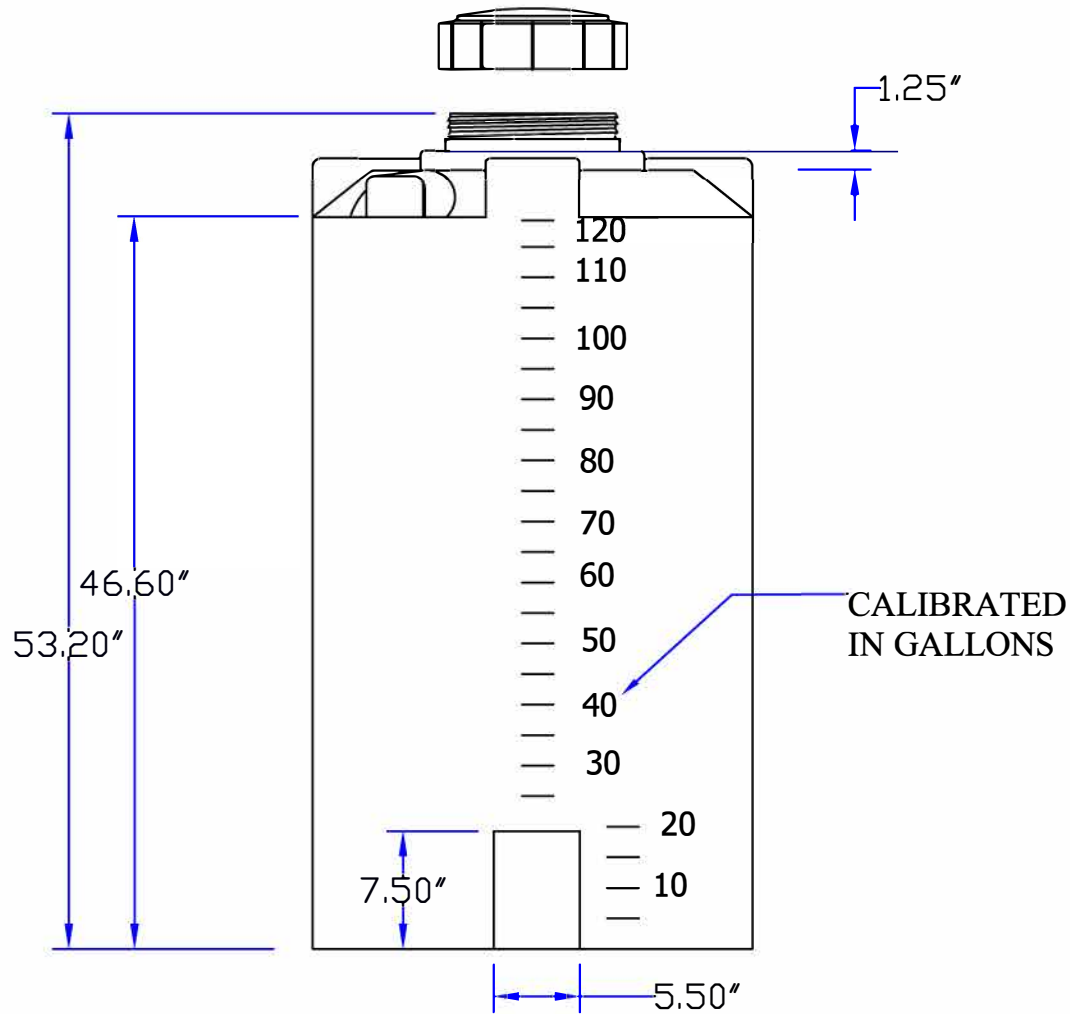

TOP VIEW

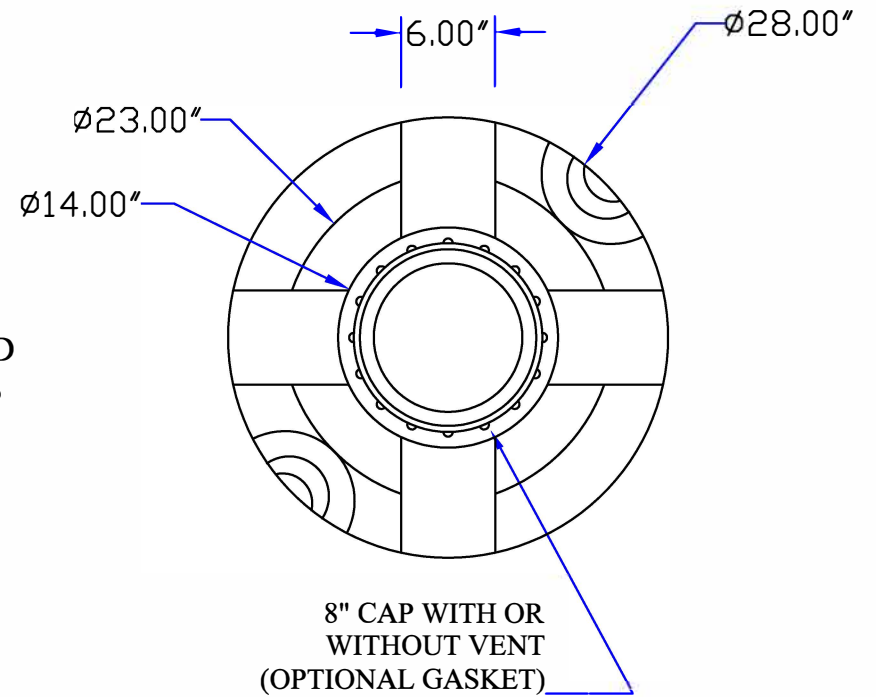

This tank is available in HDPE, Polypropylene and PVDF (Kynar).

				DRAWN / DATE MPS/04/02/03		BAILIFF ENTERPRISES, INC.	
				APPRD. / DATE			
REV	DESCRIPTION	DATE	APPRD	CLIENT / DESCRIPTION			
ALL DIMENSIONS ARE IN DECIMAL INCHES TOLERANCES UNLESS OTHERWISE SPECIFIED ± .5% ● 68° F				THIRD ANGLE PROJECTION ANSI 14.5M 		120 GALLON VERTICAL TANK	
				NOTES:		SCALE N.S.	PART NO. VTB120-28